

CD Stereo Radio Recorder

Service
Service
Service

AZ1008
all versions



Service Manual



TABLE OF CONTENTS

	chapter		chapter
Handling chip components and safety	1 - 1	TUNER BOARD	
Technical Specification & Service Tools	2 - 1	circuit diagram	8 - 1
Service Measurement	2 - 2	layout diagram	8 - 2
Connections & Controls	3 - 1	REORDER BOARD	
Instructions for use	3 - 2 to 3 - 4	circuit diagram	9 - 1
Block Diagram	4 - 1	layout diagram	9 - 2
Wiring Diagram	5 - 1	EXPLODED VIEW DIAGRAM	
FRONT BOARD		cabinet	10 - 1
circuit diagram	6 - 1	tape deck	10 - 2
layout diagram	6 - 1	Mechanical partslist	10 - 2
COMBI BOARD		Electrical partslist	11 - 1 to 11 - 3
circuit diagram	7 - 1, 7 - 3		
layout diagram	7 - 2, 7 - 4		

Safety regulations require that the set be restored to its original condition and that parts which are identical with those specified be used.

© Copyright 1995 Philips Consumer Electronics B.V. Eindhoven, The Netherlands
All rights reserved. No part of this publication may be reproduced, stored in a retrieval system or transmitted, in any form or by any means, electronic, mechanical, photocopying, or otherwise without the prior permission of Philips.

**CLASS 1
LASER PRODUCT**



PHILIPS

HANDLING CHIP COMPONENTS

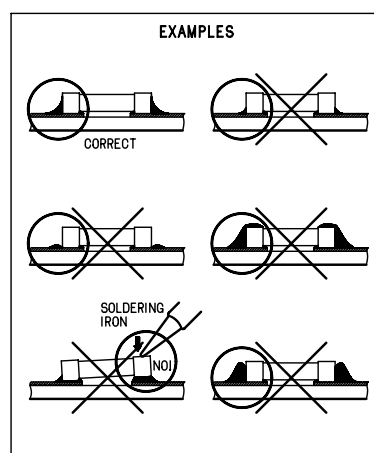
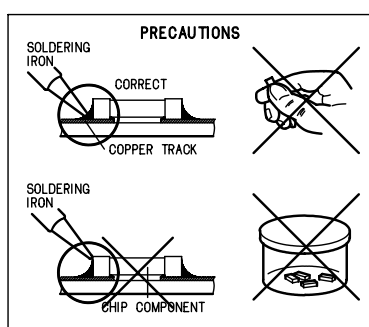
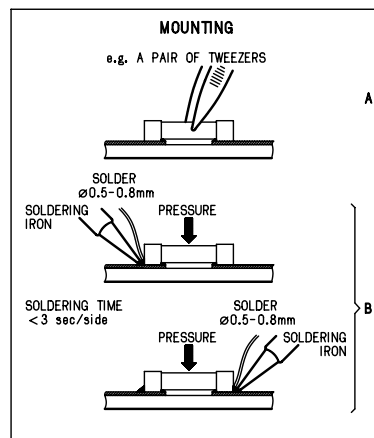
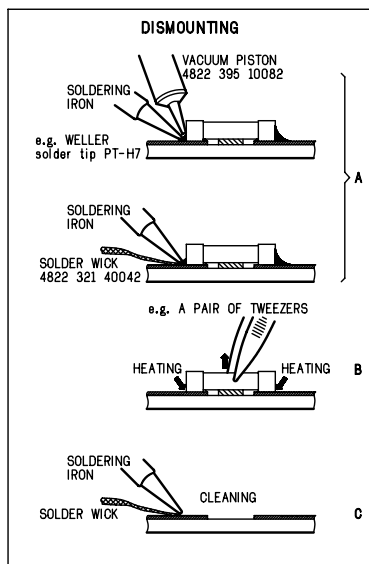
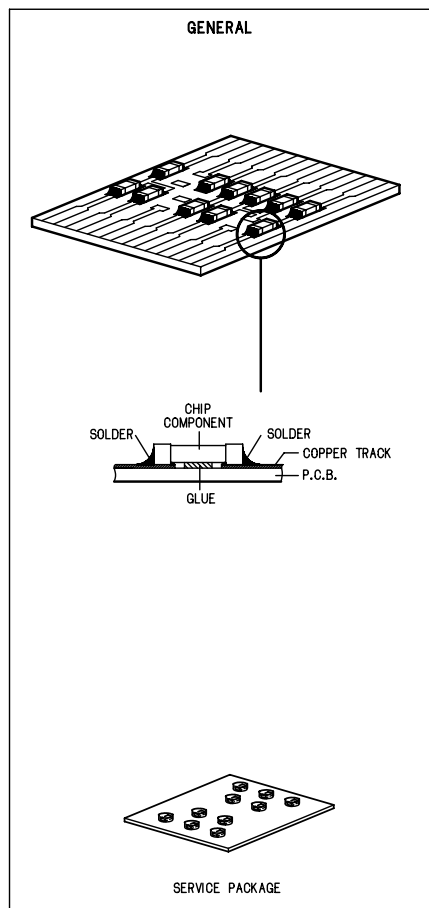
**(GB) WARNING**

All ICs and many other semiconductors are susceptible to electrostatic discharges (ESD). Careless handling during repair can reduce life drastically. When repairing, make sure that you are connected with the same potential as the mass of the set via a wristband with resistance. Keep components and tools at this potential.

ESD**(NL) WAARSCHUWING**

Alle IC's en vele andere halfgeleiders zijn gevoelig voor electrostatische ontladingen (ESD). Onzorgvuldig behandelen tijdens reparatie kan de levensduur drastisch doen verminderen. Zorg ervoor dat u tijdens reparatie via een polsband met weerstand verbonden bent met hetzelfde potentiaal als de massa van het apparaat. Houd componenten en hulpmiddelen ook op ditzelfde potentiaal.

(F) ATTENTION

Tous les IC et beaucoup d'autres semi-conducteurs sont sensibles aux décharges statiques (ESD). Leur longévité pourrait être considérablement écourtée par le fait qu'aucune précaution n'est prise à leur manipulation. Lors de réparations, s'assurer de bien être relié au même potentiel que la masse de l'appareil et enfilier le bracelet serti d'une résistance de sécurité. Veiller à ce que les composants ainsi que les outils que l'on utilise soient également à ce potentiel.

(D) WARNUNG

Alle ICs und viele andere Halbleiter sind empfindlich gegenüber elektrostatischen Entladungen (ESD). Unvorsichtige Behandlung im Reparaturfall kann die Lebensdauer drastisch reduzieren. Sorgen Sie dafür, daß Sie im Reparaturfall über ein Pulsarmband mit Widerstand mit dem Massepotential des Gerätes verbunden sind. Halten Sie Bauteile und Hilfsmittel ebenfalls auf diesem Potential.

(I) AVVERTIMENTO

Tutti IC e parecchi semi-conduttori sono sensibili alle scariche statiche (ESD). La loro longevità potrebbe essere fortemente ridotta in caso di non osservazione della più grande cauzione alla loro manipolazione. Durante le riparazioni occorre quindi essere collegato allo stesso potenziale che quello della massa dell'apparecchio tramite un braccialetto a resistenza. Assicurarsi che i componenti e anche gli utensili con quali si lavora siano anche a questo potenziale.

(GB)

Safety regulations require that the set be restored to its original condition and that parts which are identical with those specified be used. Safety components are marked by the symbol .

(F)

Les normes de sécurité exigent que l'appareil soit remis à l'état d'origine et que soient utilisées les pièces de rechange identiques à celles spécifiées. Les composants de sécurité sont marqués .

SAFETY**(D)**

Bei jeder Reparatur sind die geltenden Sicherheitsvorschriften zu beachten. Der Originalzustand des Gerätes darf nicht verändert werden. Für Reparaturen sind Originalersatzteile zu verwenden. Sicherheitsbauteile sind durch das Symbol  markiert.

(NL)

Veiligheidsbepalingen vereisen, dat het apparaat in zijn oorspronkelijke toestand wordt teruggebracht en dat onderdelen, identiek aan de gespecificeerde, worden toegepast. De Veiligheidsonderdelen zijn aangeduid met het symbool .

(I)

Le norme di sicurezza estigono che l'apparecchio venga rimesso nelle condizioni originali e che siano utilizzati i pezzi di ricambio identici a quelli specificati. Componenti di sicurezza sono marcati con .

(GB) DANGER: Invisible laser radiation when open. AVOID DIRECT EXPOSURE TO BEAM.

(S) Varning !

Osynlig laserstrålning när apparaten är öppnad och spårren är urkopplad. Betrakta ej strålen.

Advarsel !

Usynlig laserstrålning ved åbning når sikkerhedsafbrydere er ude af funktion. Undgå udsættelse for strålning.

**(FIN) Varoituis !**

Avatussa laitteessa ja suojalukituksen ohitettaessa olet alttiina näkymättömälle laserisäteilylle. Älä katso säteeseen !

(GB)

After servicing and before returning the set to customer perform a leakage current measurement test from all exposed metal parts to earth ground, to assure no shock hazard exists. The leakage current must not exceed 0.5mA.

(F)

"Pour votre sécurité, ces documents doivent être utilisés par des spécialistes agréés, seuls habilités à réparer votre appareil en panne".

TECHNICAL SPECIFICATIONS

GENERAL

Mains voltage	-/00/05/14 : 230 V
	-/10 : 240 V
	-/01/11/16 : 120 / 230 V
	-/17 : 120 V
Mains frequency	-/00/05/10/14 : 50 Hz
	-/01/11/16 : 50 / 60 Hz
	-/17 : 60 Hz
Battery	mains : 9 V (R14 x 6)
Power consumption	: 5 W
Dimension (W x H x D)	: 400 x 235 x 173mm
Weight	: 3 Kg

AMPLIFIER

Output power	mains : 2 x 1 W
	battery : 2 x 1 W
Speaker impedance	: 2 x 8 ohm
Frequency response	: 70 Hz - 3 kHz (± 3 dB)

TUNER - FM SECTION

Tuning range	: 87.35 - 108.25 MHz
	-/17 : 87 - 108.5 MHz
IF frequency	: 10.7 MHz \pm 0.2 MHz
Sensitivity	: 17 dB at 26dB S/N
Selectivity	: 24 dB at 300kHz
IF rejection	: 65 dB
Image rejection	: 26 dB

TUNER - AM SECTION

Tuning range	: 512 - 1635 kHz
	-/17 : 520 - 1730 kHz
IF frequency	: 468 kHz \pm 3 kHz
Sensitivity	: 1500 μ V/m at 26dB S/N
Selectivity	: 20 dB
IF rejection	: 70 dB
Image rejection	: 32 dB

AUDIO CASSETTE RECORDER

Number of tracks	: 1 stereo
Tape speed	: 4.76 cm/sec \pm 3%
Wow & flutter	: < 0.35% JIS WTD
Fast wind/rewind C60	: 130 sec.
Frequency response	P/B : 125 - 8000 Hz
S/N ratio	: 36 dB

COMPACT DISC

S/N ratio	: 55 dB
Channel difference	1 kHz : 2 dB
Channel crosstalk	1 kHz : 40 dB
THD	1 kHz : 0.2 %

SERVICE TOOLS

Audio signal disc SBC 429.....	4822 397 30184
Playability test disc SBC 444.....	4822 397 30245
Test disc 5 (disc without errors) +	
Test disc 5A (disc with dropout errors, black spots and fingerprints)	
SBC 426/426A.....	4822 397 30096
Burn in test disc (65 min. 1kHz signal at -30 dB level without "pause").....	4822 397 30155
Universal test cassette Fe SBC 420.....	4822 397 30071

AVAILABLE ESD PROTECTION EQUIPMENT

anti-static table mat	large 1200x650x1.25mm	4822 466 10953
	small 600x650x1.25mm	4822 466 10958
anti-static wristband		4822 395 10223
connection box (3 press stud connections, 1M)		4822 320 11307
extendible cable (2m, 2M , to connect wristband to connection box)		4822 320 11305
connecting cable (3m, 2M , to connect table mat to connection box)		4822 320 11306
earth cable (1M , to connect any product to mat or to connection box)		4822 320 11308
KIT ESD3 (combining all 6 prior products - small table mat)		4822 310 10671
wristband tester		4822 344 13999

SERVICE MEASUREMENTS

Tuner FM

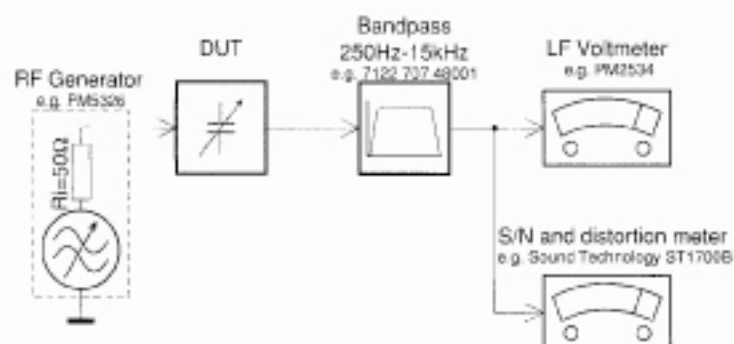

Use a bandpass filter to eliminate hum (50Hz, 100Hz) and disturbance from the pilotone (19kHz, 38kHz).

Tuner AM (MW,LW)

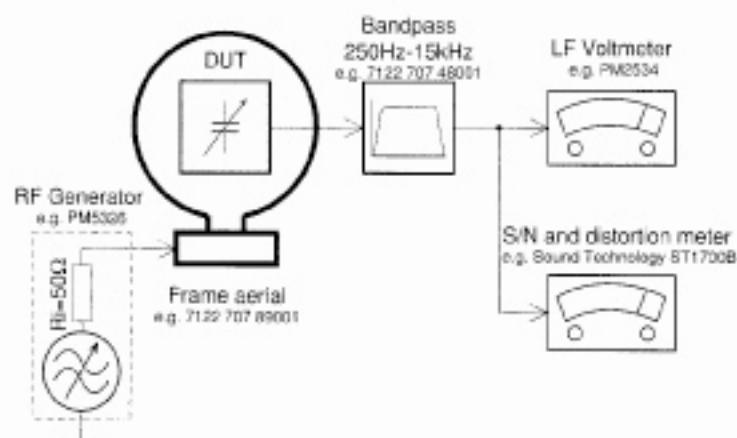

To avoid atmospheric interference all AM-measurements have to be carried out in a Faraday's cage. Use a bandpass filter (or at least a high pass filter with 250Hz) to eliminate hum (50Hz, 100Hz).

CD

Use Audio Signal Disc SBC429 4822 397 30184
(replaces test disc 3)

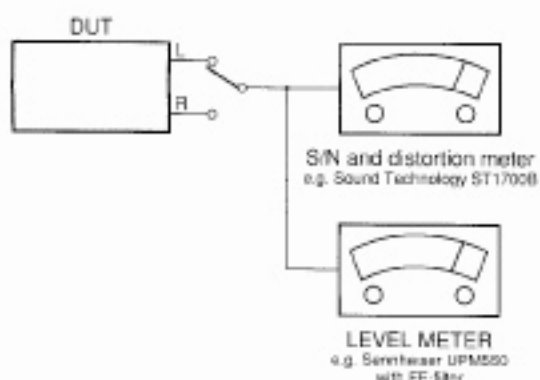

RECORDER

Use Universal Test Cassette Fe SBC420 4822 397 30071

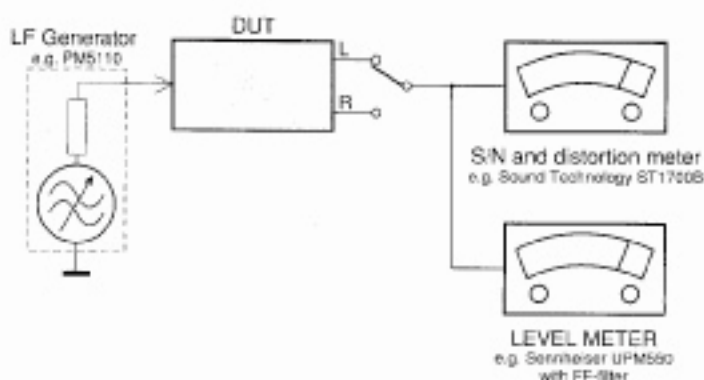

Controls

- Top and front panels**
- LIFT TO OPEN** — opens/ closes the CD door
 - Source selector: CD, AM, FM, TAPE/OFF** — selects CD source of sound, tuner waveband or tape source of sound — power on/ off switch
 - CASSETTE RECORDER:**
PAUSE II — pauses recording or playback
STOP•OPEN — stops the tape; opens the cassette door
SEARCH ◀◀ or ▶▶ — fast rewinds / winds the tape
PLAY ▶ — starts playback
RECORD ● — starts recording
CD display — shows the CD functions
 - TUNING**
 - PLAY•PAUSE** ▶|| — starts or pauses CD playback
 - STOP** ■ — stops CD playback; erases a CD programme
 - SEARCH** ◀◀, ▶▶
 CD: skips or searches a passage/track backwards or forward
 - DBB (Dynamic Bass Boost)** — enhances bass response
 - REPEAT** — repeats a track/CD/ programme
 - PROGRAM** — programmes and reviews programmed track numbers;
 - BATT LOW** — indicator lights up if battery power running low
 - VOLUME** — adjusts volume level

Power Supply

Back Panel

- Telescopic aerial** — to improve FM reception
- Battery door** — open to insert 6 x 1.5V R14/UM2/ C-cell batteries
- AC MAINS** — inlet for mains lead
- Voltage selector** — (inside the battery compartment, not all versions) adjust the selector to match the local mains. Disconnect the mains lead if this selector has to be reset.

Power Supply

Whenever convenient, use the power supply if you want to conserve battery life.

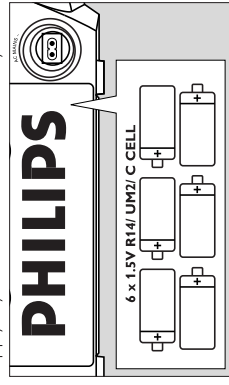

Make sure you remove the plug from the set and wall socket before inserting batteries.

Batteries (not included)

- Open the battery compartment and insert six batteries, type **R-14, UM-2** or **C-cells** (preferably alkaline) with the correct polarity as indicated by the "+" and "-" symbols inside the compartment.
- Close the compartment door, and make sure the batteries are firmly and correctly in place. The set is now ready to operate. → If **BATT LOW** lights up, battery power is running low. The **BATT LOW** indicator eventually goes out if the batteries are too weak.

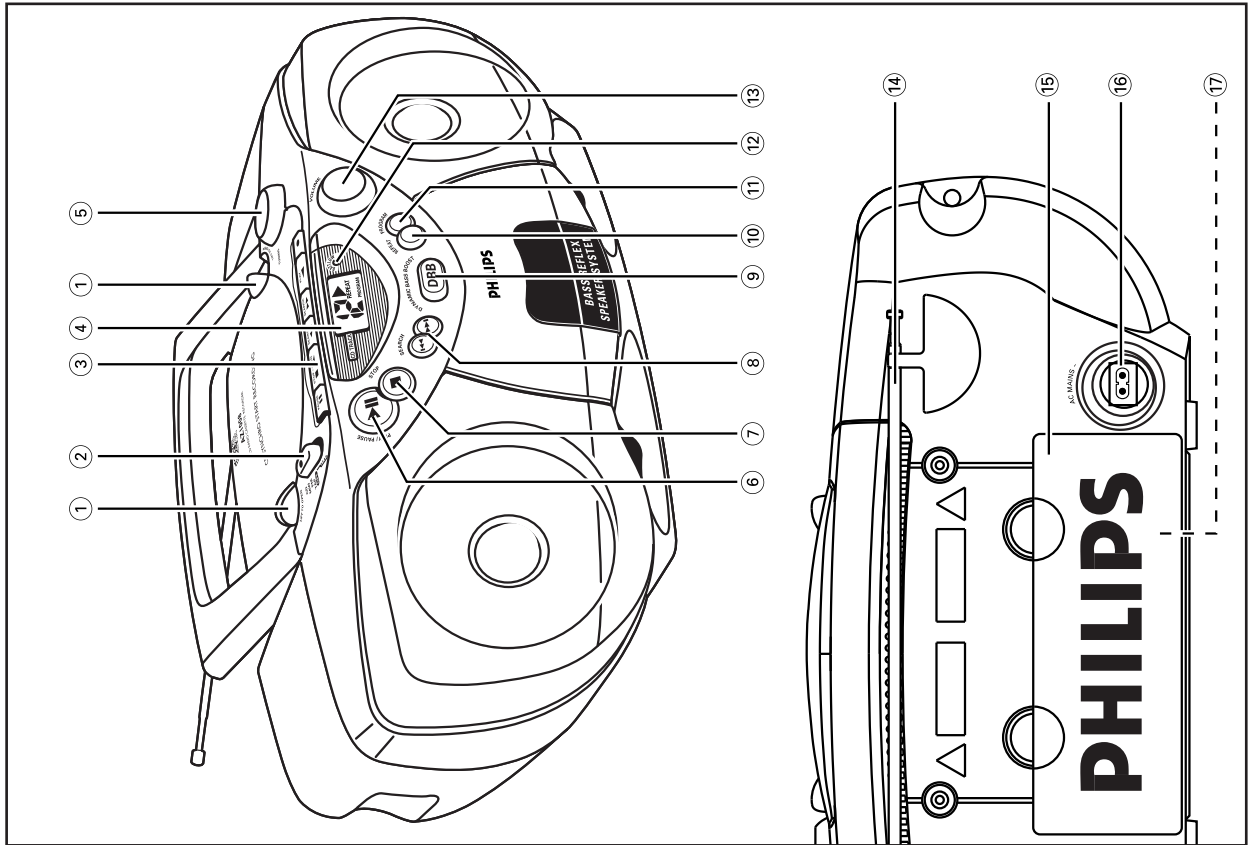

Power Supply

Batteries contain chemical substances, so they should be disposed of properly.

Incorrect use of batteries can cause electrolyte leakage and will corrode the compartment or cause the batteries to burst. Therefore:

- Do not mix battery types: e.g. alkaline with carbon zinc. Only use batteries of the same type for the set.
- When inserting new batteries, do not try to mix old batteries with the new ones.
- Remove the batteries if the set is not to be used for a long time.

Using AC Mains

- 1 Check if the mains voltage, as shown on the type plate located on the bottom of the set, corresponds to your local power supply. If it does not, consult your dealer or service centre.

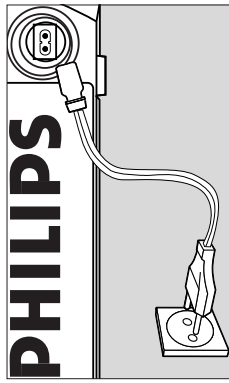

- 2 Connect the mains lead to the AC MAINS inlet and the wall socket. The power supply is now connected and ready for use.
- 3 If your set is equipped with a voltage selector, located inside the battery compartment, adjust the selector to match the local mains. Disconnect the mains lead if this selector has to be reset.

- 4 To switch off completely, unplug the mains lead from the wall socket.

- Unplug the mains lead from the wall socket to protect your set during heavy thunderstorms.

The type plate is located on the bottom of the set.

Switching power on/off: Save energy

Whether you are using mains or battery supply, to avoid unnecessary energy consumption always adjust the source selector to **TAPE/OFF** and check if the cassette keys are released.

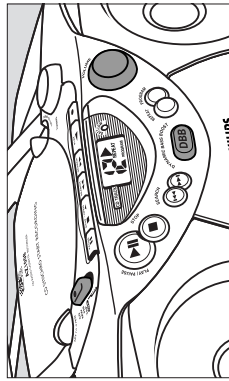

General operation

- 1 To select your sound source adjust the source selector to **CD, AM, FM** or **TAPE/OFF**.
- 2 Adjust the sound with the **VOLUME** and **DBB** (Dynamic Bass Boost) controls.
- 3 To switch off the set, adjust the source selector to **TAPE/OFF** position and check the cassette keys are released.

Radio

Radio reception

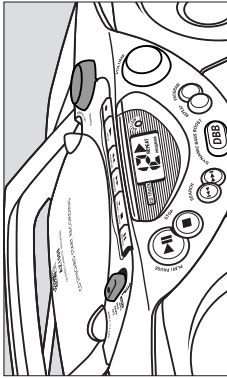

- 1 Adjust the source selector to **AM** or **FM** to select your desired waveband.
 - 2 Turn **TUNING** to tune to a radio station.
- To improve reception**
- For **FM**, pull out the telescopic aerial. Incline and turn the aerial. Reduce its length if the signal is too strong (very close to a transmitter).
 - For **AM** the set is provided with a built-in aerial so the telescopic aerial is not needed. Direct the aerial by turning the whole set.

- 3 To switch off the radio, adjust the source selector to **TAPE/OFF** position and check the cassette keys are released.

CD Player

Display indication for CD functions:

- **---**: flashes when CD source just selected
- **In stop mode**: total track number
- **During CD playback**: ▶ and current track number
- REPEAT/ REPEAT ALL**: when the respective repeat mode is activated
- **PROGRAM**: when CD programme active
- **---** and **PROGRAM**: flashes when programme memory full
- **Er**: no disc/ error in CD operation or with the CD/ CD-(R) is blank or the disc is not finalised (see Troubleshooting)

CD-Player

Playing a CD

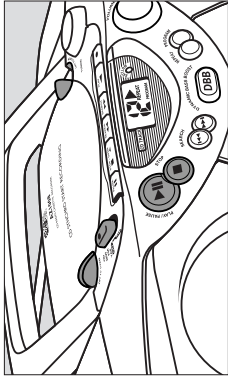

- 1 Adjust the **source selector** to **CD**.
- 2 To open the CD door, lift the CD door at the edge marked **LIFT TO OPEN**.
- 3 Insert a CD or CD-(R) with the printed side facing up and press the CD door gently close.
- 4 Press **PLAY•PAUSE ▶||** on the set to start playback.
- 5 To pause playback, press **PLAY•PAUSE ▶||**. To resume, press **PLAY•PAUSE ▶||** again. →▶ flashes during pause
- 6 To stop CD play, press **STOP ■**.
- 7 To switch off the set, adjust the source selector to **TAPE/OFF** position and check the cassette keys are released.

Note: CD play will also stop when:

- you open the CD compartment;
- you select **AM, FM** or **TAPE** sound source;
- the CD has reached to the end.

INSTRUCTIONS FOR USE

CD-Player

Selecting a different track

During playback you can use the **SEARCH** buttons to select a particular track.

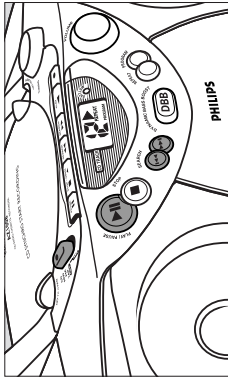

- If you have selected a track number in the stop or pause position, press **PLAY•PAUSE ►II** to start playback.
- Press **SEARCH ►I** once briefly for the next track, or press repeatedly until the desired track number appears in the display.
- Press **SEARCH ◀◀** once briefly to return to the beginning of a current track.
- Press **SEARCH ◀◀** more than once briefly for a previous track.

Finding a passage within a track

During playback, press and hold down **SEARCH ◀◀** or **►►**.

- The CD is played at high speed and low volume.

2 When you recognize the passage you want release the **SEARCH** button.
 → Normal playback resumes.

Note: When searching within a final track and you reach the end of the last track, the CD goes to stop mode.

Repeat play modes

REPEAT can be selected or changed during playback in the following sequence:

REPEAT – plays the current track continuously

REPEAT ALL – plays the entire CD continuously

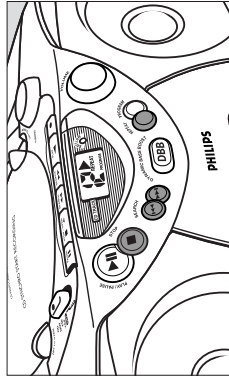

- 1 During playback, press **REPEAT** once or more until the desired REPEAT mode is shown.
- You can use **SEARCH ◀◀** or **►►** to skip tracks during the repeat modes.
- The **REPEAT** play options can be combined and used with a programme: e.g. **REPEAT ALL PROGRAM** – repeats the entire CD programme.
- 2 To return to normal playback press **REPEAT** until the REPEAT modes are no longer shown.
- You can also press **STOP ■** to quit the play mode.

CD-Player

Programming track numbers

You may store up to 19 tracks in the desired sequence. If you like, store any track more than once.

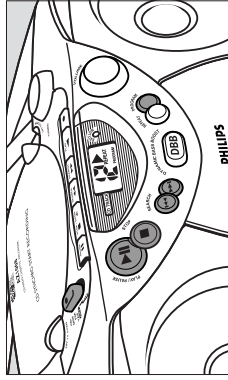

- 1 In the stop mode, press **PROGRAM** to activate programme mode.
 → **00** and **PROGRAM** flashes.
 - 2 Press **SEARCH ◀◀** or **►►** for your desired track.
 → Your selected track number and **PROGRAM** flashes.
 - 3 Press **PROGRAM** to store the track.
 → **00** and **PROGRAM** flashes, ready for your next track selection.
 - 4 Repeat steps 2 to 3 to select and store all desired tracks in this way.
 → - - and **PROGRAM** flashes in the display if you attempt to programme more than 19 tracks.
 - 5 To play your programme, press **PLAY•PAUSE ►II**.
- Reviewing your programme**
- In the stop mode, press **PROGRAM** repeatedly to see your stored track numbers.

Cassette Recorder

Erasing a programme

You can erase the contents of the memory by:

- opening the CD door;
 - selecting **AM, FM** or **TAPE** sound source;
 - pressing **STOP ■** (twice during playback or once in the stop position);
- Display: **PROGRAM** disappears.

CASSETTE RECORDER

Cassette playback

- 1 Adjust the source selector to **TAPE/OFF**.
- 2 Press **STOP•OPEN ■** to open the cassette door and insert a recorded cassette.

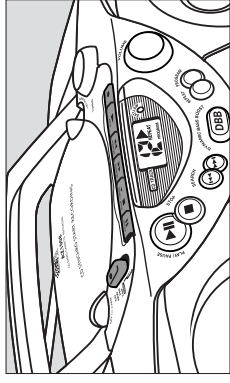

- 3 Close the cassette door.
 - 4 Press **PLAY ◀** to start playback.
 - 5 To pause playback press **PAUSE II**. To resume, press the key again.
 - 6 By pressing **SEARCH ◀◀** or **►►** fast winding of the tape is possible in both directions. To stop fast winding, press **STOP•OPEN ■**.
 - 7 To stop the tape, press **STOP•OPEN ■**.
- The keys are automatically released at the end of the tape, and the set is switched off, except if **PAUSE II** has been activated.

Recording

General information on recording

- Recording is permissible insofar as copyright or other rights of third parties are not infringed.
- This deck is not suited for recording on CHROME (IEC II) or METAL (IEC IV) type cassettes. For recording, use only NORMAL type cassettes (IEC type I) on which the tabs have not been broken.
- The best recording level is set automatically. Altering the **VOLUME** and **DBB** controls will not affect the recording in progress.
- At the very beginning and end of the tape, no recording will take place during the 7 seconds when the leader tape passes the recorder heads.
- To protect a tape from accidental erasure, have the tape in front of you and break out the left tab. Recording on this side is no longer possible. To record over this side again, cover the tabs with a piece of adhesive tape.

Synchro Start CD recording

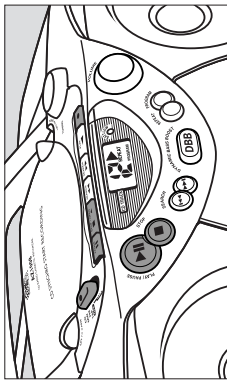
- Select CD source.
- 
- Insert a CD and if desired, programme track numbers.
 - Press **STOP•OPEN** to open the cassette door. Insert a blank tape.
 - Close the cassette door.
 - Press **RECORD** to start recording.

- Playing of the CD programme starts automatically from the beginning of the programme. It is not necessary to start the CD player separately.

- For brief interruptions press **PAUSE II**. To resume recording, press **PAUSE II** again.
- To stop recording, press **STOP•OPEN**.
→ The CD player goes to pause mode. Press **PLAY•PAUSE** to resume CD playback, or press **STOP** to stop CD play.

Selecting and recording a particular passage

- During CD playback, press and hold down the **SEARCH** buttons **◀◀** or **▶▶** on the set to find your passage.
- Press **PLAY•PAUSE** to put the CD player on pause at the selected passage.
→ Recording will begin from this exact point in the track when you press **RECORD**.

Note: If you press **RECORD** during playback, recording starts automatically from the beginning of the current track.

Recording from the Radio

- Adjust the source selector to AM or FM to select your desired waveband.
- Tune to the desired radio station (see **Radio reception**).
- Press **STOP•OPEN** to open the cassette door. Insert a blank tape.
- Close the cassette door.
- Press **RECORD** to start recording.
- For brief interruptions, press **PAUSE II**. To resume recording, press **PAUSE II** again.
- To stop recording, press **STOP•OPEN**.

Troubleshooting

If a fault occurs, first check the points listed below before taking the set for repair. Do not open the set as there is a risk of electric shock.

If you are unable to remedy a problem by following these hints, consult your dealer or service centre.

WARNING: Under no circumstances should you try to repair the set yourself, as this will invalidate the guarantee.

Problem	Solution
No sound	– Adjust the VOLUME
No power	– Mains lead not securely connected. – Connect AC mains lead properly – Batteries exhausted /incorrectly inserted. – Insert (fresh) batteries correctly
Display does not function properly/ No reaction to operation of any of the controls	– Electrostatic discharge – Switch off and unplug the set. Reconnect after a few seconds.
Err indication	– No CD inserted, insert a CD – CD badly scratched/ dirty. – Replace/ clean CD (see maintenance) – CD-(R) is blank or the disc is not finalized. – Use a finalized CD-(R) – Laser lens steamed up. – Wait until lens has cleared/acclimatized
CD playback does not work	– CD badly scratched/ dirty. Replace/ clean CD (see maintenance)
The CD skips tracks	– CD damaged or dirty. Replace or clean CD. – Programme is active. Quit programme mode
Poor cassette sound quality	– Dust and dirt on the heads, etc. – Clean deck parts, see maintenance. – Use of incompatible cassette types (METAL or CHROME). Only use NORMAL (IEC I) for recording
Recording does not work	– Cassette tab(s) may be broken. Apply a piece of adhesive tape over the missing tab space.

BLOCK DIAGRAM

4-1

4-1

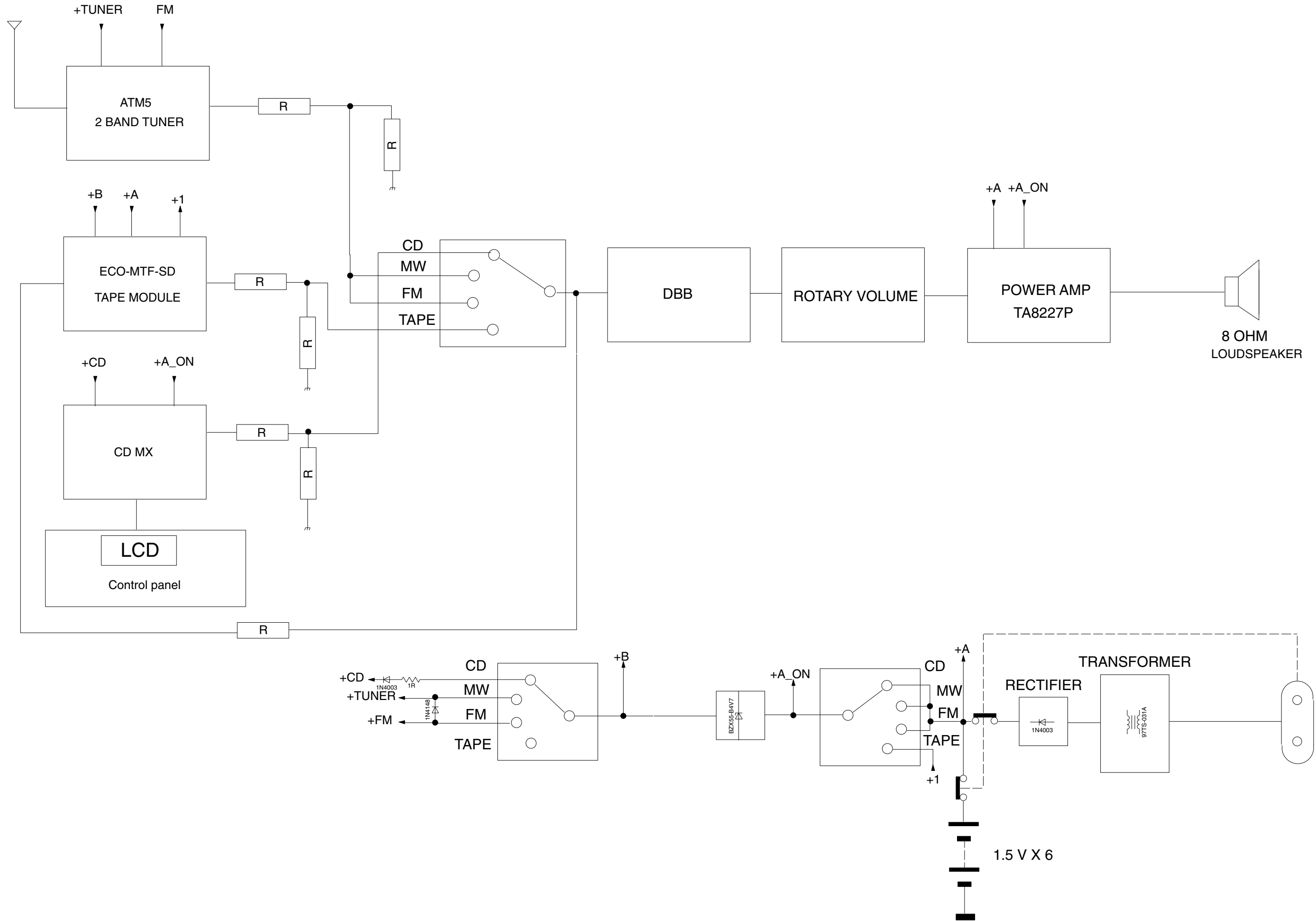

WIRING DIAGRAM

5-1

5-1

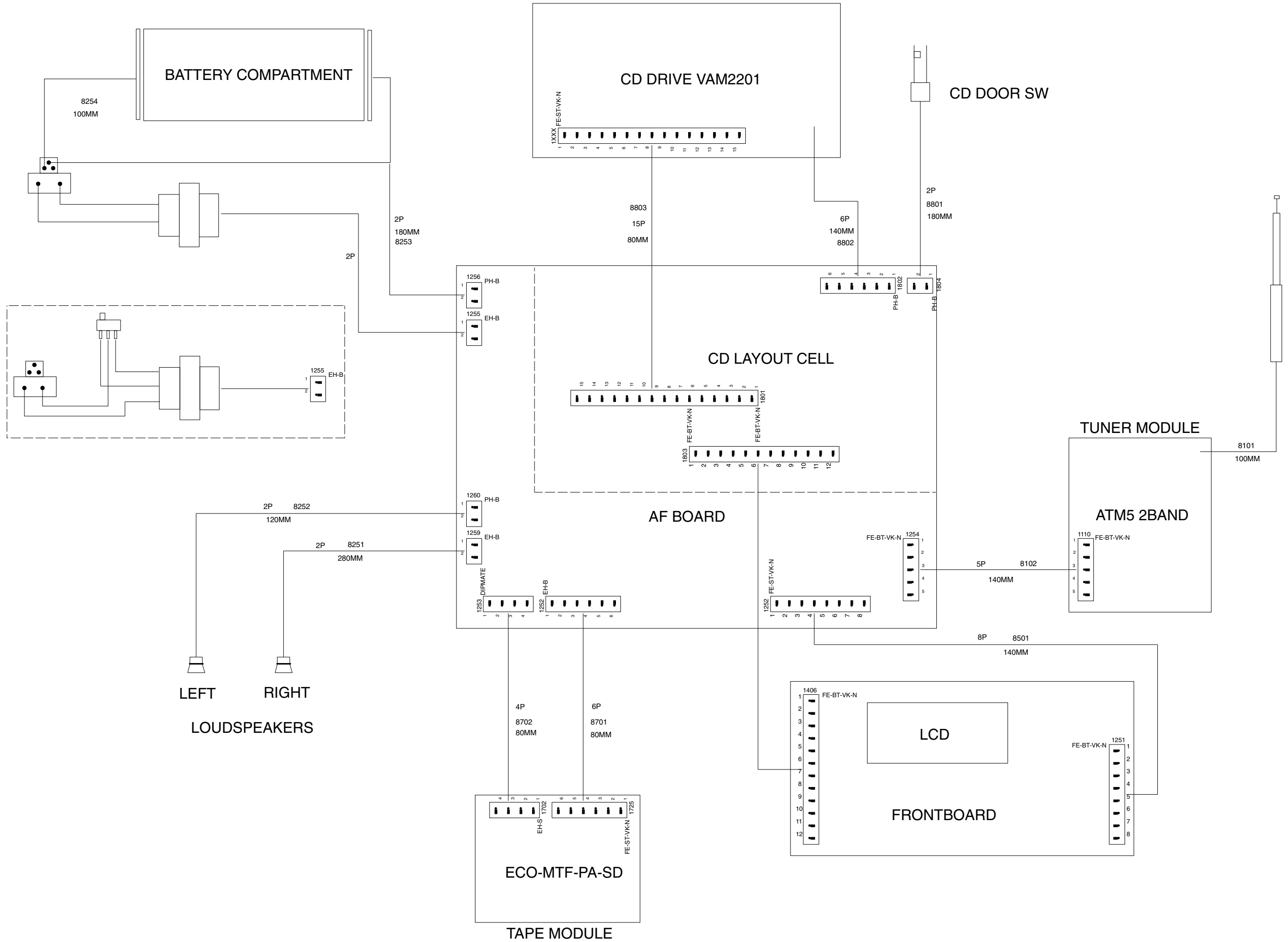

FRONT BOARD - CIRCUIT DIAGRAM

6-1

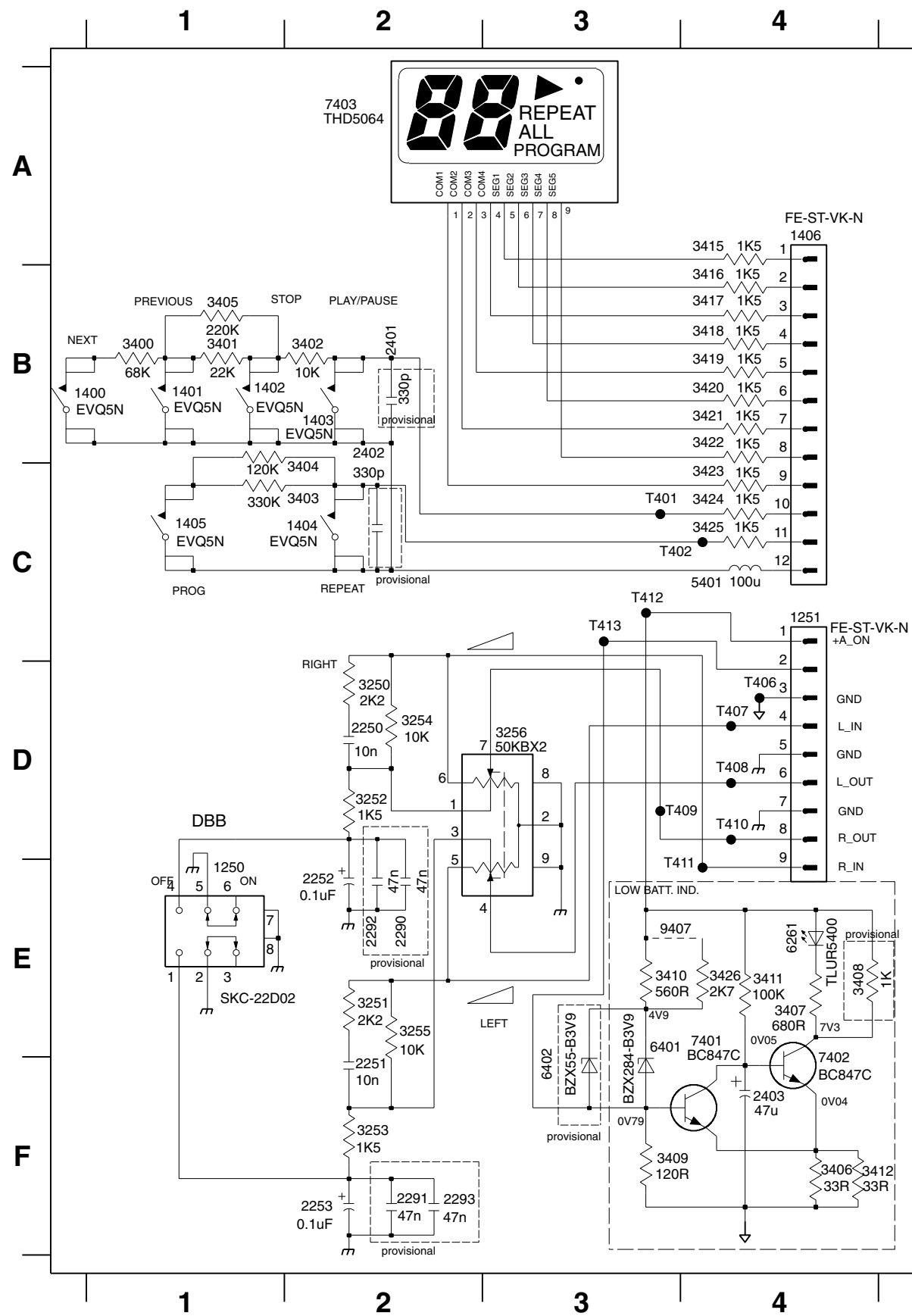

- 1250 E1
- 1251 C4
- 1400 B1
- 1401 B1
- 1402 B1
- 1403 B2
- 1404 C2
- 1405 C1
- 1406 A4
- 2250 D2
- 2251 F2
- 2252 E2
- 2253 F2
- 2401 B2
- 2402 C2
- 2403 F4
- 3250 D2
- 3251 E2
- 3252 D2
- 3253 F2
- 3254 D2
- 3255 E2
- 3256 D3
- 3400 B1
- 3401 B1
- 3402 B2
- 3403 C2
- 3404 C2
- 3405 B1
- 3406 F4
- 3407 E4
- 3408 E4
- 3409 F3
- 3410 E3
- 3411 E4
- 3412 F4
- 3415 A4
- 3416 B4
- 3417 B4
- 3418 B4
- 3419 B4
- 3420 B4
- 3421 B4
- 3422 B4
- 3423 C4
- 3424 C4
- 3425 C4
- 3426 E4
- 5401 C4
- 6261 E4
- 6401 F3
- 6402 F3
- 7401 E4
- 7402 F4
- 7403 A2
- 9407 E3
- T401 C3
- T402 C3
- T406 D4
- T407 D4
- T408 D4
- T409 D4
- T410 D4
- T411 E3
- T412 C3
- T413 C3

FRONT BOARD - LAYOUT DIAGRAM

6-1

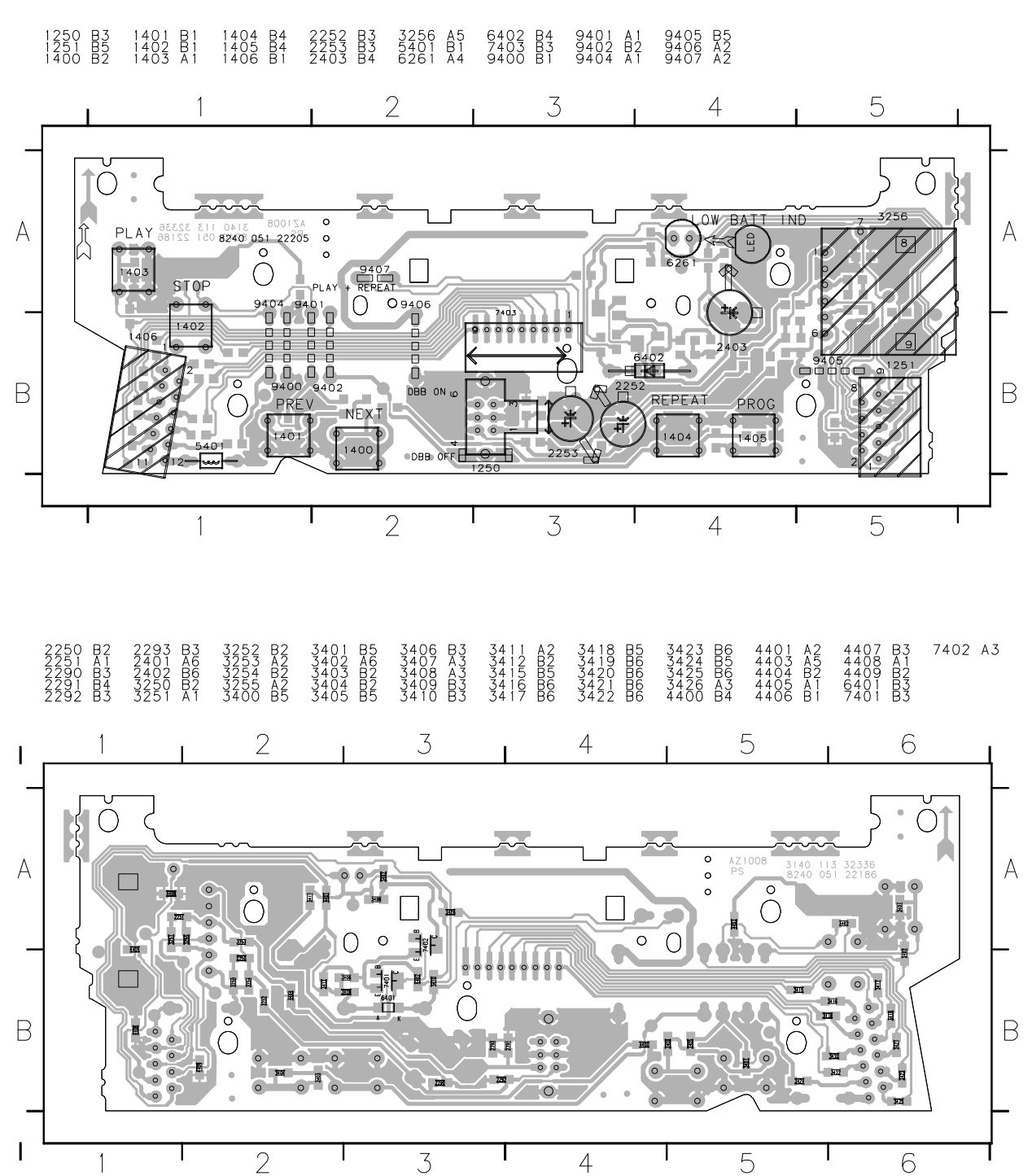

- 2250 B2
- 2251 A1
- 2252 B3
- 2293 B3
- 2401 A6
- 2402 B6
- 2403 B5
- 3250 B2
- 3251 A1
- 3252 B2
- 3253 B2
- 3254 B2
- 3255 B2
- 3401 B5
- 3402 A6
- 3403 B5
- 3404 B5
- 3405 B5
- 3406 B3
- 3407 A6
- 3408 A6
- 3409 B3
- 3410 B3
- 3411 A2
- 3412 B3
- 3413 B3
- 3414 B3
- 3415 B3
- 3416 B3
- 3417 B3
- 3418 B3
- 3419 B3
- 3420 B3
- 3421 B3
- 3422 B3
- 3423 B3
- 3424 B3
- 3425 B3
- 3426 B3
- 4401 A2
- 4403 A5
- 4404 B2
- 4405 A1
- 4406 B1
- 4407 B3
- 4408 A1
- 4409 B3
- 4410 B3
- 7401 B3
- 7402 A3

COMBI BOARD (Control / CD Part) - CIRCUIT DIAGRAM

7-1

7-1

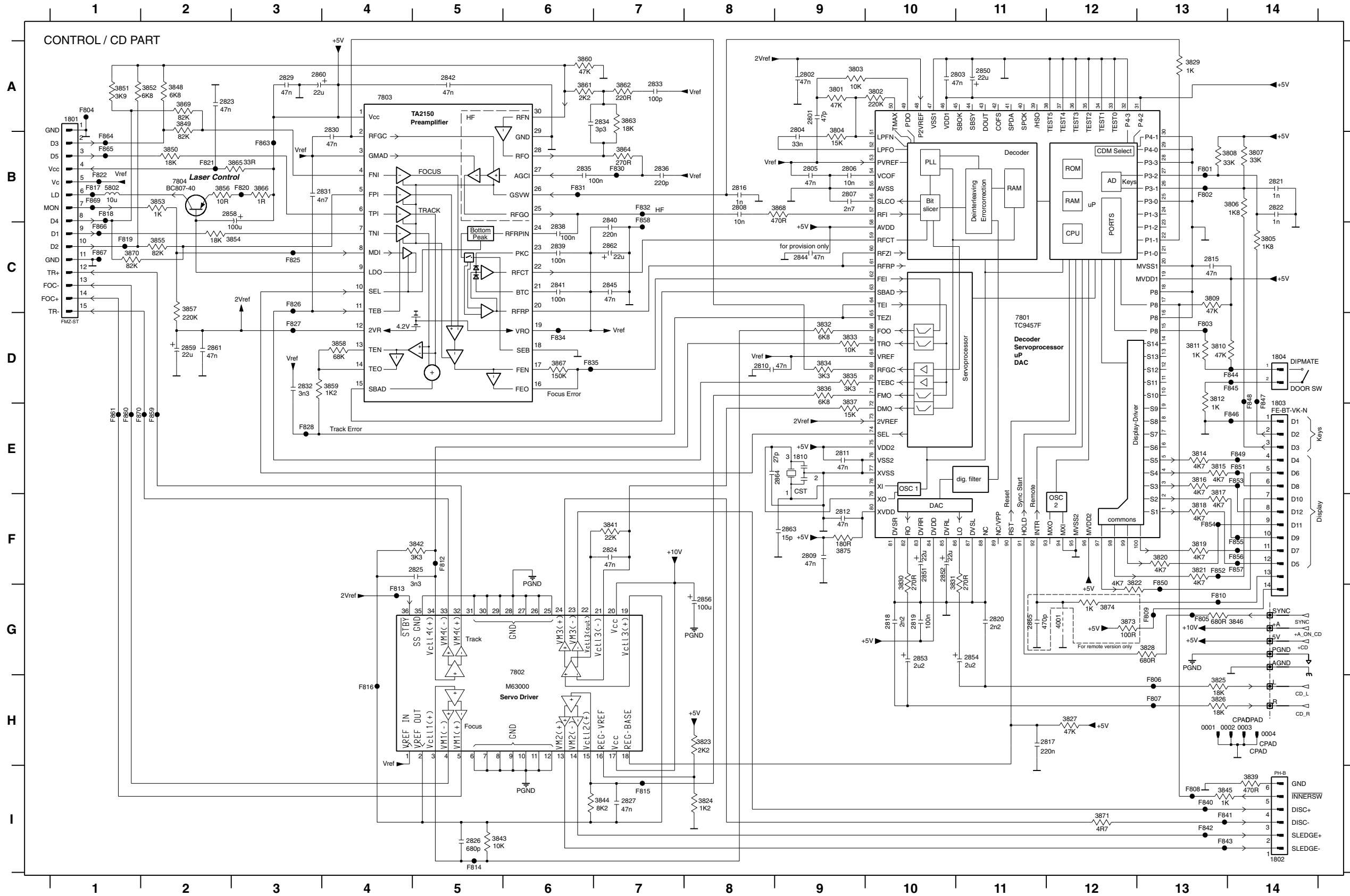

L H14	3850 B2
R H14	3851 A1
+A G14	3852 A1
5V G14	3853 B2
0001 H13	3854 C3
0002 H13	3855 C2
0003 H14	3856 B2
0004 H14	3857 C2
1801 A1	3858 D4
1802 H14	3859 D3
1803 E14	3860 A6
1804 D14	3861 A6
1810 E9	3862 A7
2801 A9	3863 A7
2802 A9	3864 B7
2803 A10	3865 B3
2804 B9	3866 B3
2805 B9	3867 D6
2806 B9	3868 B9
2807 B9	3869 A2
2808 B8	3870 C1
2809 F9	3871 I12
2810 D8	3873 G12
2811 E9	3874 G12
2812 F9	3875 F9
2815 C13	4001 G12
2816 B8	5802 B1
2817 H11	7801 D11
2818 G10	7802 G6
2819 G10	7803 A4
2820 G11	7804 B2
2821 B14	A GND G14
2822 B14	F901 B13
2823 A2	F902 B13
2824 F7	F803 D13
2825 F5	F804 A1
2826 I5	F805 G13
2827 I7	F806 H13
2829 A3	F807 H13
2830 B4	F808 I13
2831 B3	F809 G13
2832 D3	F810 G13
2833 A7	F812 F5
2834 A6	F813 G4
2835 B6	F814 I5
2836 B7	F815 I7
2838 C6	F816 H4
2839 C6	F817 B1
2840 C7	F818 B1
2841 C6	F819 C1
2842 A5	F820 B3
2844 C9	F821 B2
2845 C7	F822 B1
2850 A11	F825 C3
2851 F10	F826 C3
2852 F10	F827 D3
2853 G10	F828 E3
2854 G10	F830 B7
2856 G8	F831 B6
2858 B2	F832 B7
2859 D2	F834 D6
2860 A3	F835 D6
2861 D2	F840 I13
2862 C7	F841 I13
2863 F8	F842 I13
2864 E9	F843 I13
2865 G11	F844 D14
3801 A9	F845 D14
3802 A10	F846 E14
3803 A9	F847 D14
3804 B9	F848 D14
3805 C14	F849 E14
3806 B14	F850 G13
3807 B14	F851 E14
3808 B13	F852 F13
3809 C13	F853 E14
3810 D13	F854 F13
3811 D13	F855 F14
3812 D13	F856 F14
3814 E13	F857 F14
3815 E13	F858 C7
3816 E13	F859 E2
3817 F13	F860 E1
3818 F13	F861 E1
3819 F13	F863 B3
3820 F13	F864 B1
3821 F13	F865 B1
3822 G12	F866 C1
3823 H8	F867 C1
3824 I8	F869 B1
3825 H13	F870 E2
3826 H13	PGND G14
3827 H12	SYNC G14
3828 G13	
3829 A13	
3830 F10	
3831 F10	
3832 D9	
3833 D9	
3834 D9	
3835 D9	
3836 D9	
3837 E9	
3839 I14	
3841 F7	
3842 F5	
3843 I5	
3844 I6	
3845 I13	
3846 G14	
3848 A2	
3849 A2	

COMBI BOARD - CIRCUIT DIAGRAM

1252 B2	1256 G4	2254 B10	2258 B11	2262 C12	2267 H10	2271 G6	2276 C8	2281 C10	3260 B3	3264 D3	3268 C11	3274 H9	3279 H9	3289 G7	3294 B3	3298 C8	6250 D3	6254 F5	6259 G7	6263 H10	7251 B12	7256 G9	9236 B8	T253 G4	T258 A6	T262 A12	T266 B2	T270 C3	T274 E3	T278 A9	T282 C7	T286 G10
1253 D2	1257 A4	2255 B10	2259 B12	2263 B13	2268 F5	2272 C11	2277 E6	3257 B3	3261 A4	3265 B10	3269 A11	3275 E7	3280 F6	3291 H7	3295 A3	3299 B13	6251 A12	6255 G5	6260 G10	6264 C8	7253 F8	7257 C8	T250 F4	T254 F6	T259 B7	T263 B13	T267 A4	T271 D3	T275 E2	T279 B4	T283 D8	T287 H10
1254 D2	1258 A9	2256 C11	2260 C12	2264 C13	2269 G5	2273 A11	2278 C3	3258 C3	3262 A4	3266 B10	3270 D8	3277 G10	3286 E6	3292 B3	3296 C7	3300 C13	6252 F5	6257 G10	6261 C3	6265 E5	7254 E8	7260 G9	T251 G4	T255 C7	T260 B9	T264 C13	T268 B2	T272 D2	T276 E2	T280 B4	T284 G7	T288 H10
1255 F4	1259 B13	2257 B11	2261 B13	2265 A12	2270 F6	2274 C2	2279 C8	3259 A3	3263 E3	3267 B11	3272 C4	3278 F7	3287 F7	3293 A3	3297 C7	5200 B3	6253 G5	6258 G7	6262 H10	7250 A12	7255 E8	9235 B7	T252 G4	T256 F11	T261 B9	T265 B2	T269 B3	T273 D3	T277 A9	T281 A9	T285 G7	T289 G7

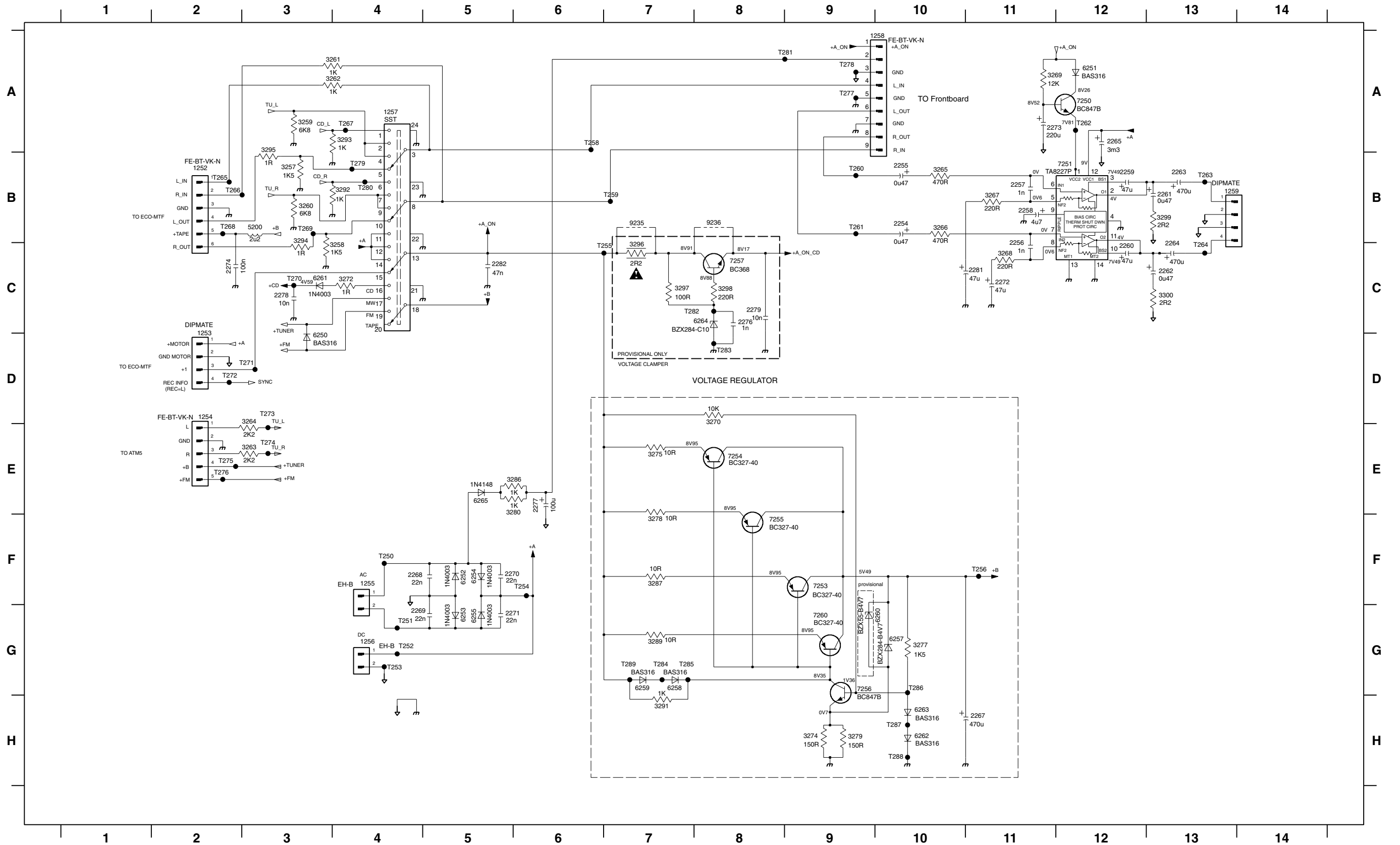

TUNER BOARD ATM5 - CIRCUIT DIAGRAM

8-1

8-1

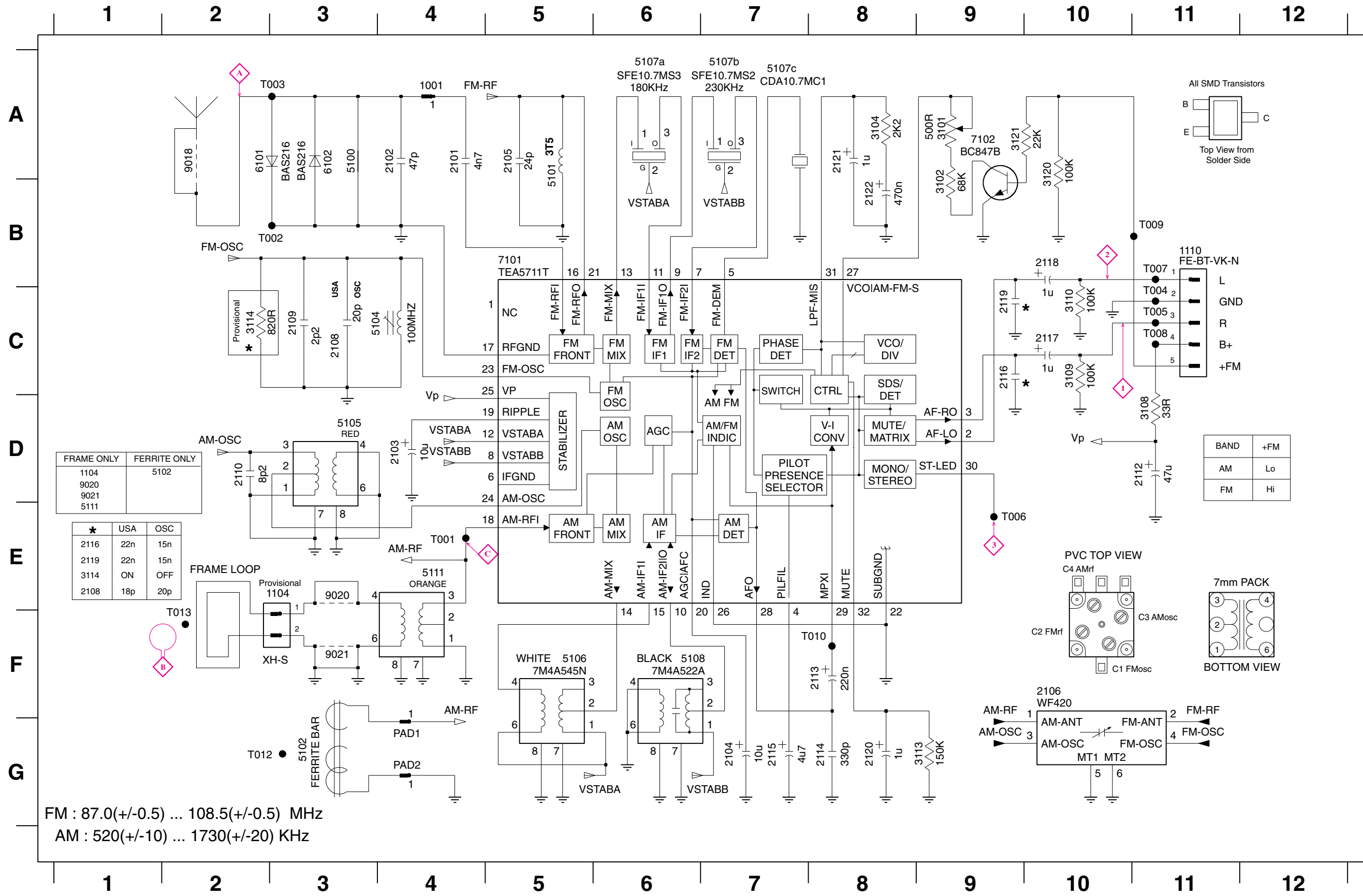

- 1001 A4
- 1104 E3
- 1110 B11
- 2101 A4
- 2102 A4
- 2103 D4
- 2104 G7
- 2105 A5
- 2106 F10
- 2108 C3
- 2109 C3
- 2110 D2
- 2112 D11
- 2113 F8
- 2114 G8
- 2115 G7
- 2116 C9
- 2117 C10
- 2118 B10
- 2119 C9
- 2120 G8
- 2121 A8
- 2122 B8
- 3101 A9
- 3102 B9
- 3104 A8
- 3108 D11
- 3109 C10
- 3110 C10
- 3113 G9
- 3114 C2
- 3120 A10
- 3121 A9
- 5100 A3
- 5101 A5
- 5102 G3
- 5104 C4
- 5105 D3
- 5106 F5
- 5107a A6
- 5107b A7
- 5107c A7
- 5108 F7
- 5111 E4
- 6101 A2
- 6102 A3
- 7101 B5
- 7102 A9
- 9018 A2
- 9020 E3
- 9021 F3
- T001 E4
- T002 B3
- T003 A3
- T004 B11
- T005 C11
- T006 E9
- T007 B11
- T008 C11
- T009 B11
- T010 F8
- T012 G2
- T013 F2

FM : 87.0(+/-0.5) ... 108.5(+/-0.5) MHz
 AM : 520(+/-10) ... 1730(+/-20) KHz

RECORDER BOARD - CIRCUIT DIAGRAM

9-1

9-1

71	D15	1707	C 3	1709	A14	2706	B 4	2711	F 6	2719	C 8	2727	F 7	2733	H13	2750	D 6	3703	D 3	3712	E 7	3720	F 7	3730	F12	3743	C 9	3761	G 6	7705	G 4	8702	E 1	9753	C13	T705	B14	T710	G11	T718	E 2	T724	E 2
73	E15	1707	C 7	1710	E15	2707	B 4	2712	F 6	2721	C 8	2728	F 7	2734	G10	2751	H 6	3704	C 3	3713	F 7	3722	F 7	3731	F12	3744	C 9	3762	D 6	7705	G 4	8704	E 1	9754	F11	T706	E14	T711	G11	T719	H13	T725	C 7
74	G 9	1707	C 7	1725	A15	2708	B 4	2714	C 3	2722	C 8	2729	C13	2735	G10	2760	F14	3706	D 4	3714	F 7	3723	F 7	3732	H13	3747	G12	5701	F11	8702	F 1	8704	E 1	9758	D12	T707	B10	T712	F14	T721	A14	T722	G 7
1702	G15	1707	E 9	2703	G 7	2709	G12	2715	D 5	2723	G 8	2730	G11	2738	B 3	2799	E15	3707	B 5	3716	H 8	3726	E 9	3733	F 6	3748	B 2	6704	F11	8702	F 1	8705	F15	T701	A14	T708	B10	T716	F10	T722	G 7		
1707	F 3	1707	E12	2704	C 7	2710	G12	2716	D 5	2726	G 8	2732	G12	2739	B 1	3701	B 6	3710	D 5	3719	H 8	3727	E 9	3734	D11	3749	B 2	7702	H13	8702	E 1	8705	F15	T702	A14	T709	D14	T717	F 2	T723	F 2		

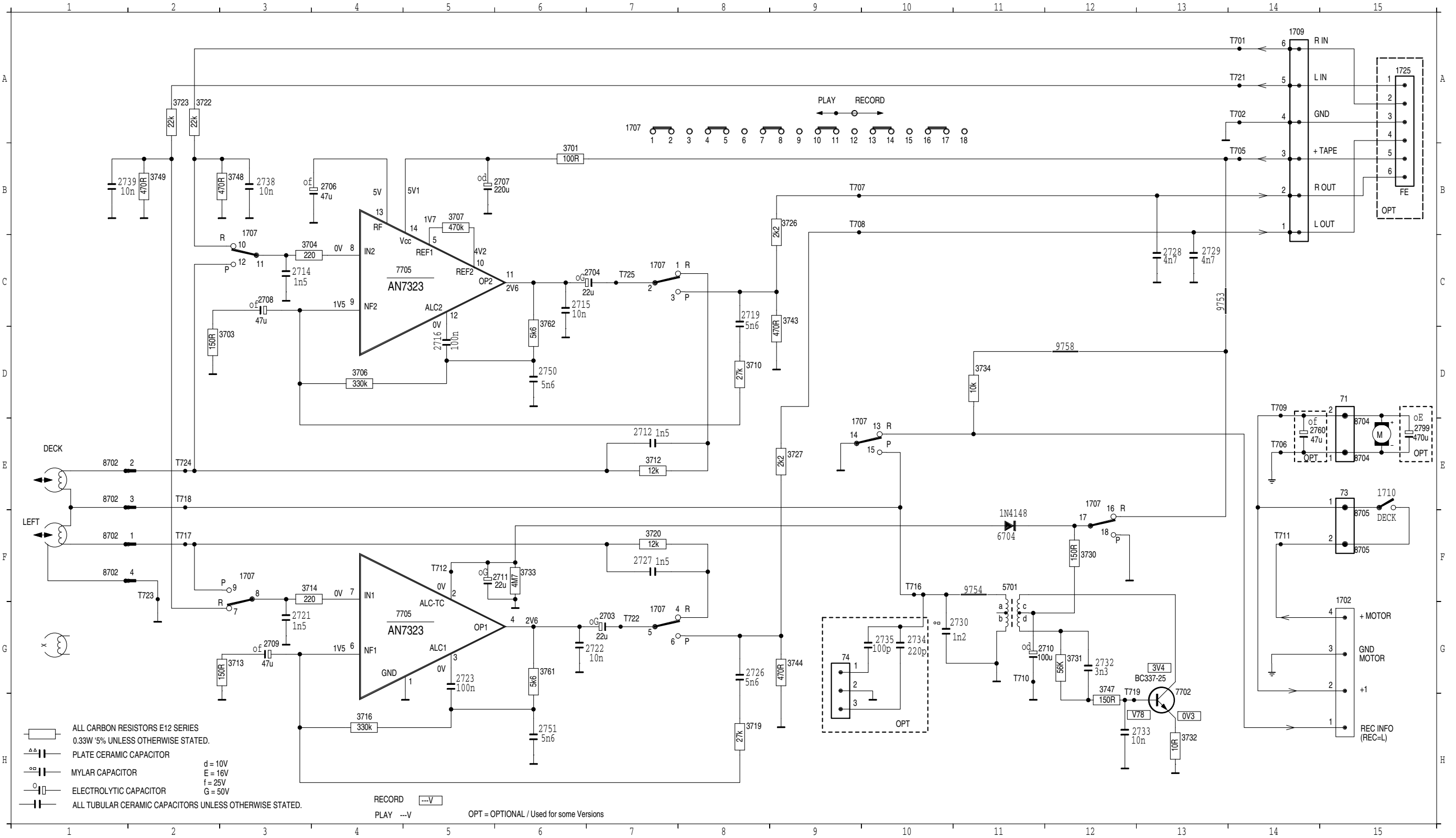

RECORDER BOARD - LAYOUT DIAGRAM

9-2

9-2

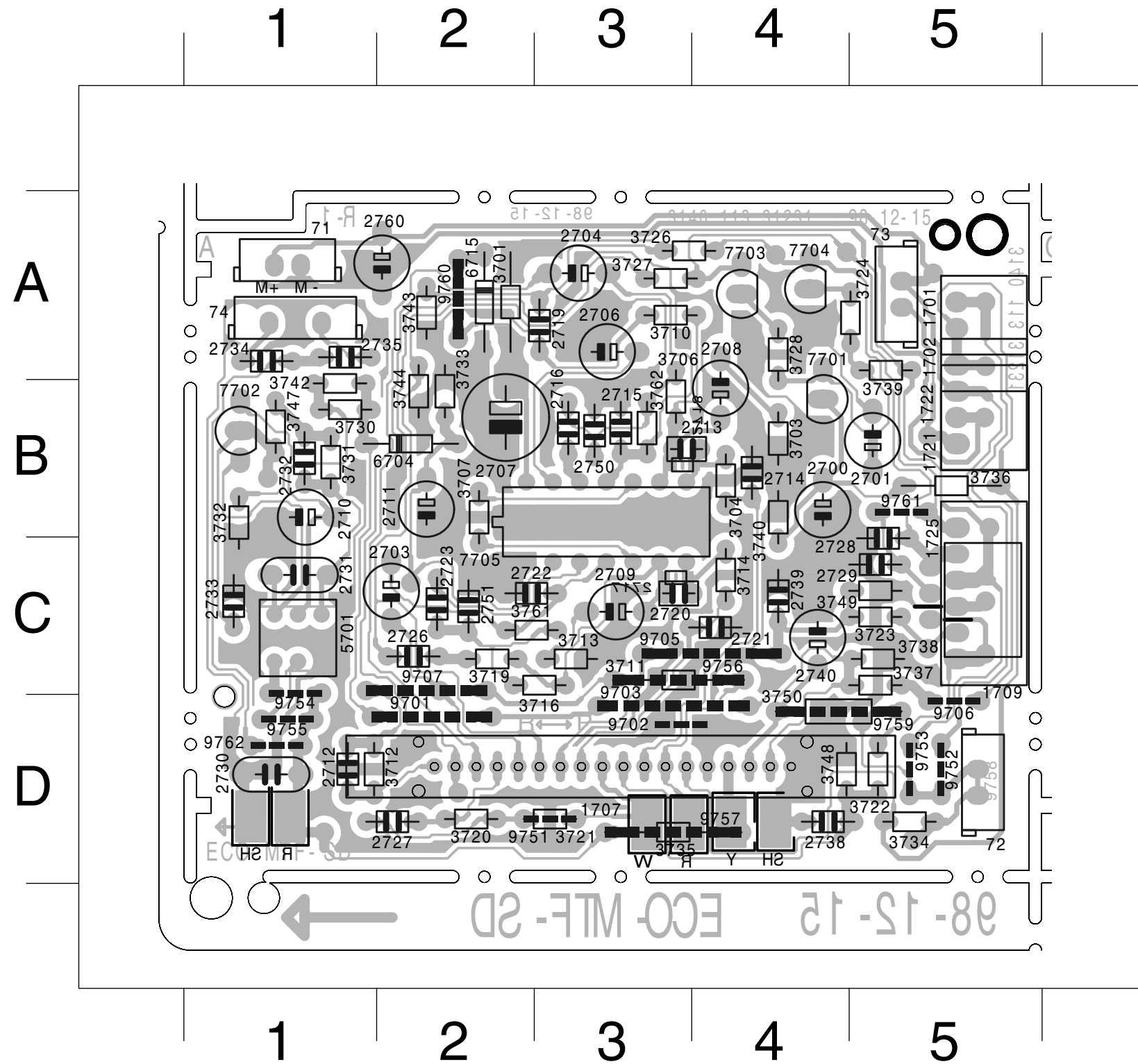

71 A 1	2729 C 5	3733 B 2	9756 C 3
72 D 5	2730 D 1	3734 D 5	9757 D 3
73 A 5	2731 C 1	3735 D 3	9759 D 4
74 A 1	2732 B 1	3736 B 5	9760 A 2
1701 A 5	2733 C 1	3737 C 5	9761 B 5
1702 B 5	2734 A 1	3738 C 5	9762 D 1
1707 D 3	2735 A 1	3739 A 5	T701 C 5
1709 C 5	2738 D 4	3740 B 4	T702 C 5
1721 B 5	2739 C 4	3742 B 1	T705 B 5
1722 B 5	2740 C 4	3743 A 2	T706 B 5
1725 C 5	2750 B 3	3744 B 2	T709 A 5
2700 B 4	2751 C 2	3747 B 1	T710 C 1
2701 B 5	2760 A 2	3748 D 4	T711 B 5
2703 C 2	3701 A 2	3749 C 5	T712 C 2
2704 A 3	3703 B 4	3750 D 4	T713 A 5
2706 A 3	3704 B 4	3761 C 2	T714 D 5
2707 B 2	3706 B 3	3762 B 3	T715 D 5
2708 B 4	3707 B 2	5701 C 1	T716 D 1
2709 C 3	3710 A 3	6704 B 2	T719 B 1
2710 B 1	3711 C 3	6715 A 2	T720 A 5
2711 B 2	3712 D 1	7701 B 4	T721 C 5
2712 D 1	3713 C 3	7702 B 1	T722 C 2
2713 B 3	3714 C 4	7703 A 4	T725 D 2
2714 B 4	3716 C 3	7704 A 4	T7707 A 4
2715 B 3	3719 C 2	7705 B 3	T7708 A 4
2716 B 3	3720 D 2	9701 D 2	
2717 C 3	3721 D 3	9702 D 3	
2718 B 3	3722 D 5	9703 D 3	
2719 A 3	3723 C 5	9705 C 4	
2720 C 3	3724 A 5	9706 D 5	
2721 C 4	3726 A 3	9707 C 2	
2722 C 2	3727 A 3	9751 D 3	
2723 C 2	3728 A 4	9752 D 5	
2726 C 2	3730 B 1	9753 D 5	
2727 D 2	3731 B 1	9754 C 1	
2728 C 5	3732 B 1	9755 D 1	

CASSETTE ADJUSTMENT

Adjustment	Cassette	SK	Deck 1	Measure on	Read on	Adjust with	Adjust to
Azimuth	10 kHz SBC420*	Tape	Play	H/P Jack	mV meter	Left hand Screw R/P head	max.
Motor Speed	3150 kHz SBC420*	Tape	Play	H/P Jack	Wow and flutter meter	Preset in motor	**a

* SBC420 : 4822 397 30071

**a The maximum permissible speed deviation is $\pm 3\%$.
Moreover, the wow and flutter value can be read.

EXPLODED VIEW DIAGRAM - CABINET

10-1

10-1

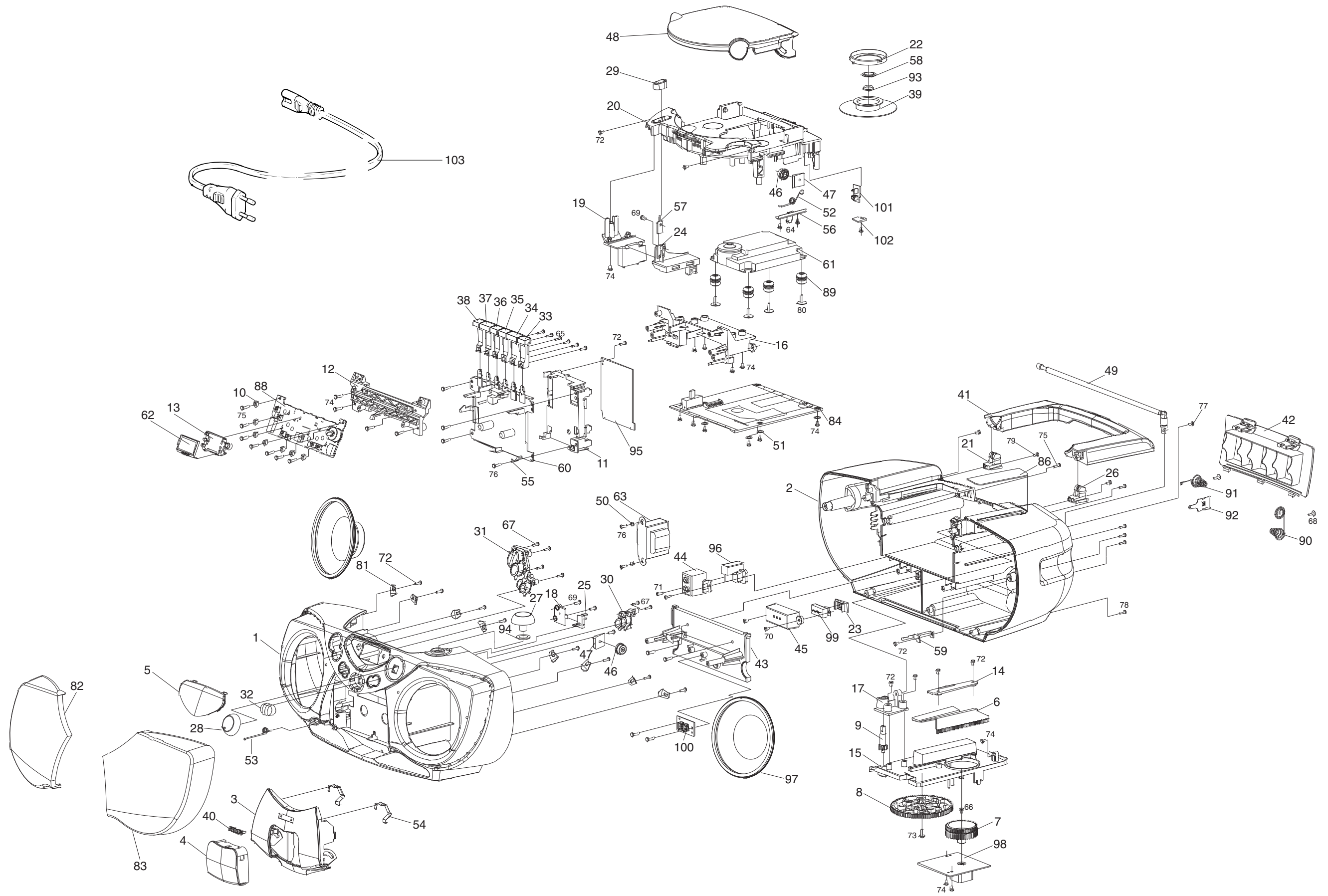

MECNICAL PARTSLIST - CABINET

3	9965 000 07504	Cass Door	49	9965 000 07512	Rod Antenna
4	9965 000 07479	Cass Door Lens	52	9965 000 07505	CD Door Spring
6	9965 000 07480	Pointer	53	9965 000 07506	Cass Door Spring
7	9965 000 07481	Gear PVC	54	9965 000 07507	Cass Tape Spring
8	9965 000 07482	Gear Big	60	4822 691 10612	Tape Deck
9	9965 000 07483	Gear Tuning Knob	61	9305 022 30103	CD Drive VAM2201/03
11	3140 114 20430	Bracket Recording	89	4822 529 10431	Damper Rubber (25 DEG)
13	9965 000 07484	LCD Bracket	90	9965 000 07508	Battery Spring "+,-"
14	9965 000 07485	Pointer Holder	91	9965 000 07509	Battery Spring "-"
18	9965 000 07486	DBB Knob Plate	92	9965 000 07510	Battery Contact Plate "+"
21	9965 000 07487	Handle Hinge Adaptor (L)	93	9965 000 07655	Magnet
22	9965 000 07653	Stabilizer Ring	103	4822 321 10249	Mains Cord (For -/00/01/11/14/16)
26	9965 000 07488	Handle Hinge Adaptor (R)	103	9965 000 07586	Mains Cord (For -/05)
27	9965 000 07489	Tuning Knob	103	4822 321 10954	Mains Cord (For -/10)
28	9965 000 07490	Volume Knob	103	4822 321 11466	Mains Cord (For -/17)
29	9965 000 07491	Selector Knob	3140 111 20800	Spring Recording	
30	9965 000 07492	Repeat/Program Key	4822 256 90463	Ferrite Bar Holder	
31	9965 000 07493	Play/Stop/FF/Rew Key	9965 000 07566	Instruction Manual (For -/00/05)	
32	9965 000 07494	DBB Knob	9965 000 07584	Instruction Manual (For -/01/10/11/16)	
33	9965 000 07495	Cass Knob (Record)	9965 000 07590	Instruction Manual (For -/14)	
34	9965 000 07496	Cass Knob (Play)	9965 000 07511	Instruction Manual (For -/17)	
35	9965 000 07497	Cass Knob (Rewind)			
36	9965 000 07498	Cass Knob (F.F.)			
37	9965 000 07499	Cass Knob (Stop/Eject)			
38	9965 000 07500	Cass Knob (Pause)			
39	9965 000 07654	Stabilizer			
41	9965 000 07501	Handle			
42	9965 000 07502	Battery Door			
46,47	4822 529 10322	Damper Assy			
48	9965 000 07503	CD Door			

Note: Only these parts mentioned in the list are normal service parts.

MECNICAL PARTSLIST - TAPE DECK

10	4822 528 70849	Pinch Roller Arm (B)	4822 528 11189	Pinch Roller Assy
11	4822 528 70695	Pinch Roller Assy		
74	4822 403 70968	Eject Hook (A)		
106	4822 358 31325	Main Belt 45.2 x 1.2		
107	4822 358 31124	Sub Belt 44.7 x 1.2		
110	4822 278 90721	Leaf Switch		
111	4822 249 30218	MS18R-AKONI		
112	4822 249 40306	E. Head		
115	4822 361 21656	EG-530AD-9B		

Note: Only these parts mentioned in the list are normal service parts.

EXPLODED VIEW DIAGRAM - TAPE DECK

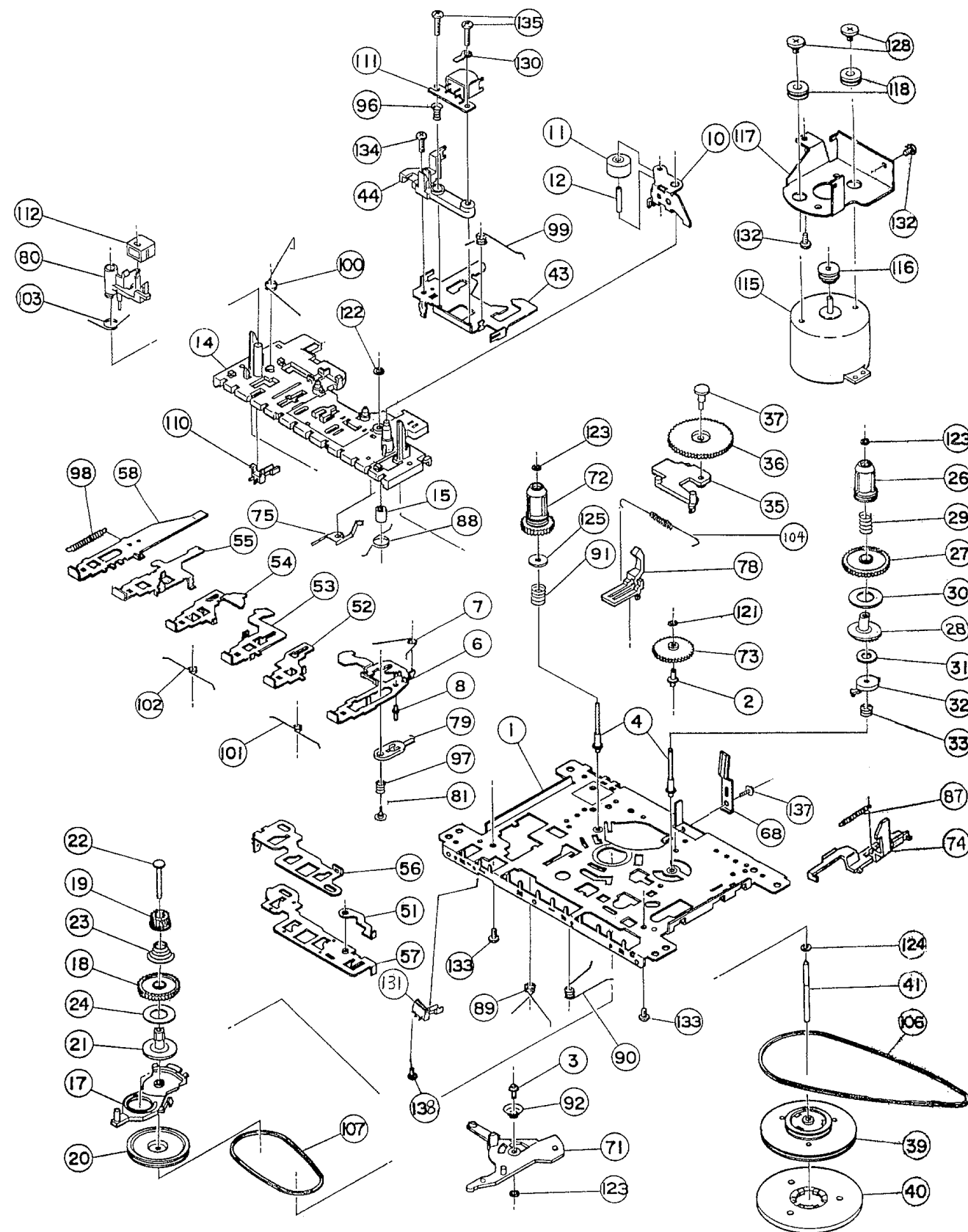

ELECTRICAL PARTSLIST - FRONT BOARD**- RESISTORS -**

3256 9965 000 07514 Rotary Volume.50KB X2

- COIL -

5401 9965 000 05604 Axial Inductor 100µH

- DIODE -

6261 9965 000 07515 LED Red

6402 9965 000 07516 Zener Diode

- TRANSISTORS -

7401 5322 130 42755 Trans BC847C

7402 5322 130 42755 Trans BC847C

- MISCELLANEOUS -

1250 9965 000 07513 Slide Switch

1400 4822 276 13797 Tact Switch

1401 4822 276 13797 Tact Switch

1402 4822 276 13797 Tact Switch

1403 4822 276 13797 Tact Switch

1404 4822 276 13797 Tact Switch

1405 4822 276 13797 Tact Switch

7403 9965 000 07517 LCD Display

Note: Only these parts mentioned in the list are normal service parts.

ELECTRICAL PARTSLIST - CD VAM BOARD**- COIL & FILTER -**

1810 4822 242 80997 Filter CST16,93MXW040-TF01

5802 9965 000 07238 Choke Coil 10mH

- IC & TRANSISTORS -

7801 9965 000 07519 IC TC9457F-014-907B-K1

7802 9965 000 07520 IC M63000SP

7803 9965 000 07521 IC TA2150FN

7804 5322 130 60123 Trans BC807-40

- MISCELLANEOUS -

1801A 9965 000 07518 FFC Cable 15P

Note: Only these parts mentioned in the list are normal service parts.

ELECTRICAL PARTSLIST - MAIN BOARD**- COIL -**

5200 4822 157 11012 Inductor 2.2µH

- DIODES -

6250 4822 130 83757 Diode BAS216

6251 4822 130 83757 Diode BAS216

6252 5322 130 30684 Diode 1N4002RL

6253 5322 130 30684 Diode 1N4002RL

6254 5322 130 30684 Diode 1N4002RL

6255 5322 130 30684 Diode 1N4002RL

6258 4822 130 83757 Diode BAS216

6259 4822 130 83757 Diode BAS216

6260 9965 000 07241 Zener 4.7V 0.5W

6261 5322 130 30684 Diode 1N4002RL

6262 4822 130 83757 Diode BAS216

6263 4822 130 83757 Diode BAS216

6265 4822 130 32778 Diode 1SS133

- IC & TRANSISTORS -

7250 4822 130 60511 Trans BC847B

7251 4822 209 31544 IC TA8227P

7253 4822 130 41327 Trans BC327-40

7254 4822 130 41327 Trans BC327-40

7255 4822 130 41327 Trans BC327-40

7256 4822 130 60511 Trans BC847B

7260 4822 130 41327 Trans BC327-40

Note: Only these parts mentioned in the list are normal service parts.

ELECTRICAL PARTSLIST - MISCELLANEOUS**- CAPACITORS -**

2001 5322 122 32654 22nF X10% 7R 63V

2002 5322 122 32654 22nF X10% 7R 63V

2003 4822 126 14043 1µF +80-20% Y5V 16V

- RESISTOR -

3002 4822 051 10008 0R 5% 0,25W

- MISCELLANEOUS -

1257 9965 000 07524 Slide Switch

1806 9965 000 07525 CD Door Switch

8102 9965 000 07526 FFC Cable 5P

8401 9965 000 07527 FFC Cable 12P

8501 9965 000 07528 FFC Cable 9P

8701 9965 000 07529 FFC Cable 6P

4822 265 10741 AC Socket (Not for -/17)

4822 265 20644 AC Socket (For -/17)

9965 000 07522 Speaker 8 Ohm 4' 3W

△ 9965 000 07567 Transformer (For -/00/10/14)

△ 9965 000 07585 Transformer (For -/01/05/11/16)

△ 9965 000 07523 Transformer (For -/17)

△ 4822 277 11887 Volt Selector (For -/01/11/16)

Note: Only these parts mentioned in the list are normal service parts.

ELECTRICAL PARTSLIST - TUNER BOARD ATM5**- CAPACITORS -**

2101	4822 126 13193	4,7nF 10% X7R	63V
2102	4822 122 33777	47pF 5% NP0	63V
2103	4822 124 40248	10µF 20%	63V
2104	4822 124 40248	10µF 20%	63V
2105	4822 126 12814	24pF 5% N220	50V
2106	4822 125 50681	Var Capacitor	
2108	2020 552 92746	20pF 5%	50V (Not for -/17)
2108	2020 552 92745	18pF 5%	50V (For -/17)
2109	2020 552 95949	2,2pF	50V
2110	4822 126 12229	8,2pF N750	50V
2112	4822 124 40433	47µF 20%	25V
2113	4822 124 40746	0,22µF 20%	63V
2114	4822 126 14241	330pF	50V
2115	4822 124 40769	4,7µ F20%	100V
2116	3198 017 31530	15nF X7R	50V (Not for -/17)
2116	4822 126 14494	22nF 10% X7R	25V (For -/17)
2117	4822 124 21913	1µF 20%	63V
2118	4822 124 21913	1µF 20%	63V
2119	3198 017 31530	15nF X7R	50V (Not for -/17)
2119	4822 126 14494	22nF 10% X7R	25V (For -/17)
2120	4822 124 21913	1µF 20%	63V
2121	4822 124 21913	1µF 20%	63V
2122	4822 124 41407	0,47µF 20%	63V

- RESISTORS -

3101	4822 100 20167	50K 30%	0,1W
3102	4822 051 30683	68K 5%	0,062W
3104	4822 051 30222	2K2 5%	0,062W
3108	4822 051 20339	33R 5%	0,1W
3109	4822 117 13632	100K 1%	0,62W
3110	4822 117 13632	100K 1%	0,62W
3113	4822 051 30154	150K 5%	0,062W
3114	4822 117 12968	820R 5%	0,62W (For -/17)
3120	4822 117 13632	100K 1%	0,62W
3121	4822 051 30223	22K 5%	0,062W
9010	4822 051 30008	Jumper	
9011	4822 051 20008	Jumper	
9012	4822 051 30008	Jumper	
9013	4822 051 30008	Jumper	
9015	4822 051 30008	Jumper	
9017	4822 051 20008	Jumper	
9018	4822 051 20008	Jumper	
9026	4822 051 30008	Jumper	

- COILS & FILTER -

5101	4822 157 70513	Coil	
5102	2422 535 94985	Ind Fxd 64µH	5%
5104	3103 308 20990	FM Coil	
5105	4822 157 71145	Coil 270µH	
5106	4822 157 70499	Coil	
5107	4822 242 81154	Filter KMFC5058-Z	
5108	4822 156 11146	Coil	

- DIODES -

6101	4822 130 83757	Diode BAS216	
6102	4822 130 83757	Diode BAS216	

- IC & TRANSISTOR -

7101	4822 209 32746	IC TEA5711T/N2	
7102	5322 130 60159	Trans BC846B	

- MISCELLANEOUS -

1110	4822 267 10954	Connector 5P	
1201	2422 549 44211	Ferrite Bar 5X13X55	

Note: Only these parts mentioned in the list are normal service parts.

ELECTRICAL PARTSLIST - RECORDER BOARD**- CAPACITORS -**

2703	4822 124 81151	22µF	50V		
2704	4822 124 81151	22µF	50V		
2706	4822 124 40433	47µF	20%	25V	
2707	4822 124 40196	220µF	20%	16V	
2708	4822 124 40433	47µF	20%	25V	
2709	4822 124 40433	47µF	20%	25V	
2710	4822 124 41584	100µF	20%	10V	
2711	4822 124 81151	22µF	50V		
2712	4822 126 12878	1,5nF	10%	16V	
2714	4822 126 12878	1,5nF	10%	16V	
2715	4822 121 51387	10nF	20%	16V	
2716	4822 126 12882	100nF	+80-20%	50V	
2719	4822 126 13098	5,6nF	20%	16V	
2721	4822 126 12878	1,5nF	10%	16V	
2722	4822 121 51387	10nF	20%	16V	
2723	4822 126 12882	100nF	+80-20%	50V	
2726	4822 126 13098	5,6nF	20%	16V	
2727	4822 126 12878	1,5nF	10%	16V	
2728	4822 126 11714	4,7nF	20%		
2729	4822 126 11714	4,7nF	20%		
2730	2020 300 90561	1,2nF	10%	50V	
2732	4822 122 10577	3,3nF	10%	16V	
2733	4822 121 51387	10nF	20%	16V	
2738	4822 121 51387	10nF	20%	16V	
2739	4822 121 51387	10nF	20%	16V	
2750	4822 126 13098	5,6nF	20%	16V	
2751	4822 126 13098	5,6nF	20%	16V	

- RESISTORS -

3701	4822 116 52175	100R	5%	0,5W	
3703	4822 116 83868	150R	5%	0,5W	
3704	4822 116 83872	220R	5%	0,5W	
3706	4822 116 52272	330K	5%	0,5W	
3707	4822 116 52285	470K	5%	0,5W	
3710	4822 116 52264	27K	5%	0,5W	
3712	4822 116 52238	12K	5%	0,5W	
3713	4822 116 83868	150R	5%	0,5W	
3714	4822 116 83872	220R	5%	0,5W	
3716	4822 116 52272	330K	5%	0,5W	
3719	4822 116 52264	27K	5%	0,5W	
3720	4822 116 52238	12K	5%	0,5W	
3722	4822 116 52257	22K	5%	0,5W	
3723	4822 116 52257	22K	5%	0,5W	
3726	4822 116 52256	2K2	5%	0,5W	

- RESISTORS -

3727	4822 116 52256	2K2	5%	0,5W	
3730	4822 116 83868	150R	5%	0,5W	
3731	4822 116 52291	56K	5%	0,5W	
3732	4822 116 52182	15R	5%	0,5W	
3733	4822 111 30893	4M7	5%	0,2W	
3734	4822 050 21003	10K	1%	0,6W	
3743	4822 116 83883	470R	5%	0,5W	
3744	4822 116 83883	470R	5%	0,5W	
3747	4822 116 83868	150R	5%	0,5W	
3748	4822 116 83883	470R	5%	0,5W	
3749	4822 116 83883	470R	5%	0,5W	
3761	4822 116 52289	5K6	5%	0,5W	
3762	4822 116 52289	5K6	5%	0,5W	

- COIL -

5701	4822 157 10371	Coil			
------	----------------	------	--	--	--

- DIODE -

6704	4822 130 30621	Diode 1N4148			
------	----------------	--------------	--	--	--

- IC & TRANSISTOR -

7702	4822 130 40981	Trans BC337-25			
7705	4822 209 17498	IC AN7323			

- MISCELLANEOUS -

1707	4822 277 11504	Push Switch			
1725	4822 265 11207	Connector Socket 6P			

Note: Only these parts mentioned in the list are normal service parts.